

# Rotator Instruction & Maintenance Manual

# C o n t e n t s

This instruction manual covers DHA's range of Gobo Rotators units. All are available in a series of fixed speeds for mains voltage operation, or as Varispeed, requiring a DC Controller. Instructions for DC controllers are covered in a separate document.

<b>1 Fixed-Speed Effect</b>	<b>3</b>
<b>2 Varispeed Effects</b>	<b>4</b>
<b>3 Gobo Rotator</b>	
Fitting	5
Using Glass Gobos in Rotators	5
Using Rotators in Strand Cantata Lanterns	6
Using Rotators in CCT Silhouette Lanterns	7
<b>4 Double Gobo Rotator</b>	<b>8</b>
The Real Time Clock	9
<b>5 Glass Gobos - General Precautions</b>	<b>14</b>
<b>6 Important Safety Notes</b>	<b>16</b>
<b>7 Moving Effects Fitting Reference</b>	<b>17</b>
<b>8 Certificates of Conformity</b>	<b>19</b>

# 1

## Fixed Speed Effects

Moving Effects with fixed speed (AC synchronous) motors are supplied for either 230V or 115V operation. These units should only be powered from non-dim circuits of the appropriate voltage. The direction of rotation may be reversed by means of a switch on the motor housing.

The nominal speed of rotation is based on a mains supply frequency of 50Hz. When used with 60Hz mains supplies, fixed speed units will rotate 20% faster than their nominal speed.

### Mains Plug Wiring (UK 13A type)

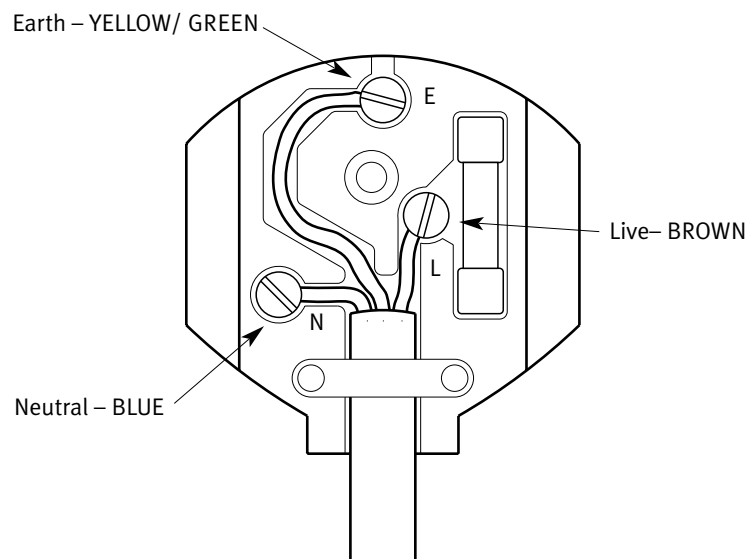

# 2

## Varispeed Effects

Moving Effects for Varispeed operation are fitted with 12V DC (asynchronous) motors. These must be powered by a DHA DC Controller which allows remote control over speed and direction of rotation.

Varispeed effects are supplied fitted with a four-pin, male XLR connector to accept two independent control signals. The device can be set to respond to either one of these signals by means of a switch on the motor box.

Note: the Double Gobo Rotator requires both signals and therefore has no channel selector switch.

# 3

## Gobo Rotators

### FITTING

It is important to ensure that the Gobo Rotator is fitted correctly in each lantern. Due to the heat from the lamp housing the rotator should be positioned so that the motor housing faces towards the lens tube and not over the lamphouse.

These units should not be run continuously, for long periods, at full intensity as heat damage may result, particularly in lanterns above 1.2kW. Particular care must be taken if the lantern is pointing upward as this places the rotator's motor directly above the lamphouse where it can rapidly become very hot.

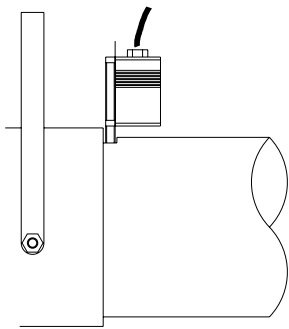

**Correct Fitting** with motor box over lens tube

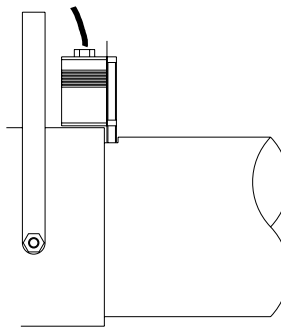

**Incorrect Fitting** with motor box over lamp housing

### USING GLASS GOBOS IN ROTATORS

To use a glass gobo the aluminium gobo-retaining ring supplied with the unit must be replaced with a thin retaining ring to allow for the extra thickness of the glass. Usual precautions for the use of glass gobos apply: The lantern should be adjusted carefully for a flat field and should be brought up to operating intensity carefully – see special instructions for glass gobos on page 14. Replacement retaining rings are available from DHA – order code B900 or B900/Thick. Smaller Gobo Rotators, for M and D-size gobos do not accept glass gobos.

## Rotators in Strand Cantata Lanterns

The gate of newer Cantata lanterns (since 1990) has a gobo retaining spring assembly which prevents insertion of gobo rotators. A simple modification to the gate, using parts supplied with the rotator, may be necessary. The new retaining spring has to be deflected to the side in order to insert the gobo holder. Older retaining springs have to be deflected towards the front of the lantern (lens tube) and do not prevent insertion of the rotator.

To remove the lens tube from lamp housing slacken the two hexagon head screws between the two sections and twist the lens tube off. It should not be necessary to slacken or remove any other screws.

Remove the existing gobo runners and retaining spring from the gate by removing the two screws shown. Attach the two adaptor plates using the same screws.

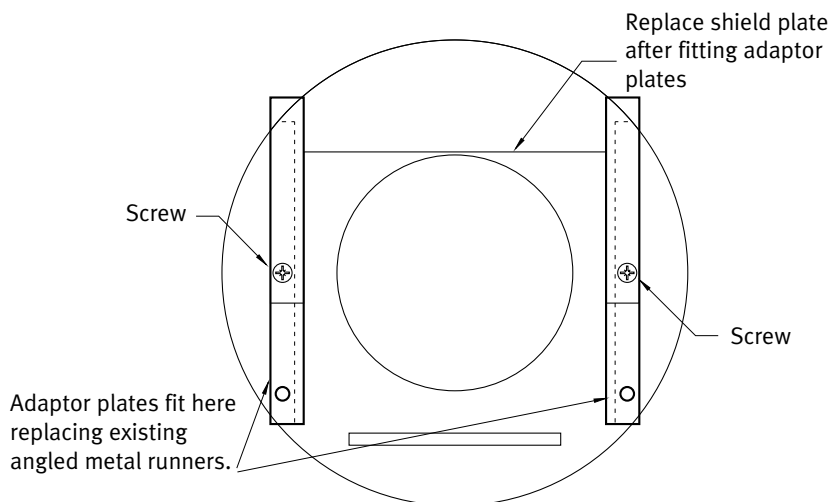

### Important Note

In order to adapt the Cantata gate it is necessary to remove a safety latch which prevents the gobo holder from falling out of the lantern. When using the lantern without this safety latch the use of a safety chain or other restraint is imperative.

## Rotators in CCT Silhouettes

(RTR 004 & RTR 204)

Where possible, when using a Gobo Rotator with a CCT Silhouette lantern, the rotator should be placed in the runners on the lens tube with the motor box facing away from the lamp housing. It should also be noted that, to fit the rotator, certain Silhouette lanterns require spacers. These will usually be supplied by CCT or can be obtained from DHA.

# 4

## Double Gobo Rotator

All of the above information applies equally to the Double Gobo Rotator. This unit, usually only supplied as Varispeed, holds two gobos and, when used in conjunction with any DHA DC controller, allows independent control of their speeds and directions.

The Double Gobo Rotator has a separate motor for each gobo; when referring to DHA control instructions, the unit should be regarded as two 'effects' requiring two DC Controller 'channels' (one for each gobo). All four conductors within the DC control cable are utilised. No splitters should be used.

The Double Gobo Rotator can hold two gobos, either glass or metal or one of each. Glass gobos are subject to the usual special precautions – see page 14.

When using metal gobos it is possible to adjust their separation. Bringing the gobos close together enables both to be in sharp focus; separating them allows one to be used off-focus to 'animate' the other and also stops mechanical interference of gobos buckled by the heat of the lantern (this may occur with some of the more 'open' gobo patterns). Separation is controlled by the positioning of the gobo retaining rings. The gobos can be spaced apart by inserting the ring under a gobo rather than on top. This gives three levels of spacing. When using glass gobos the retaining rings should be omitted.

## The Real Time Clock

This is a specially modified version of the double gobo rotator which allows a working, real-time clock to be projected from a theatre lantern. A static metal gobo (the clockface) is held between two rotating glass gobos (the hour and minute hands). The unit is powered directly from the mains and should be treated as a Fixed-Speed Effect – do not connect to a dimmer.

To set the correct time it is necessary to remove the unit from the lantern and manually rotate the gobos to the appropriate positions before switching on. The clock is mains-synchronous so its accuracy depends on the mains frequency – see Fixed-Speed Effects on page 3.

The effect can be fitted to any lantern which would normally accept the standard double gobo rotator. The lantern must also be suitable for glass gobo projection.

DHA has a range of standard clock faces and matching hands to choose from, as shown on the following pages.

### CUSTOM CLOCK DESIGNS

Custom designs can be made to order. The 'London' clock face is ideal for incorporating a custom logo in its centre. See illustrations opposite.

In addition, full colour cibachrome film of any image can be sandwiched between the clock hands and used with a metal clock face in the 70W discharge versions of the ETC Source 4 the Strand SL and the Selecon Pacific.

Clock Faces

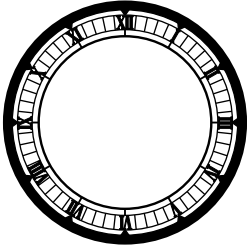

CF1 Roman

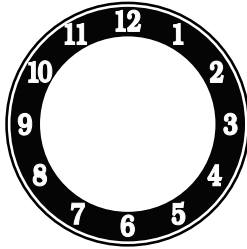

CF2 Arabic

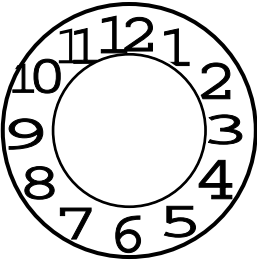

CF3 Modern

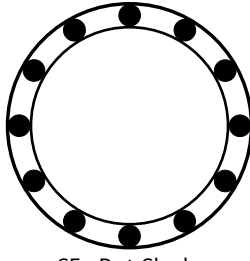

CF4 Dot Clock

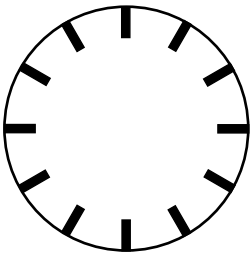

CF5 Line Clock

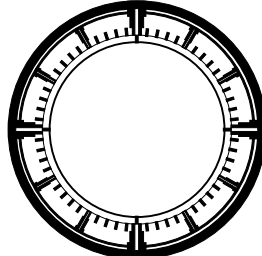

CF6 Stylised

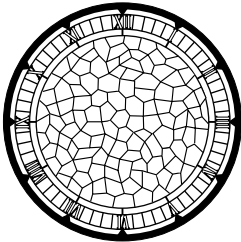

CF7 London

Clock Hands

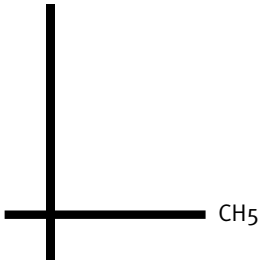
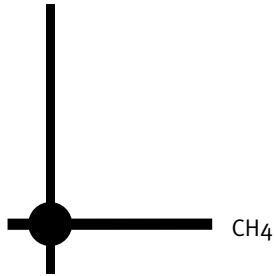
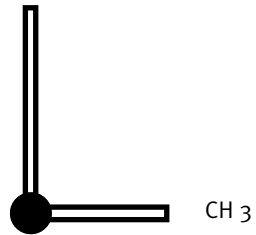
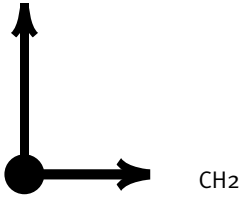
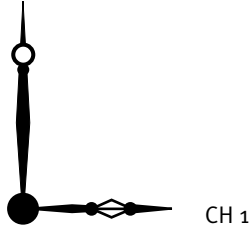

CH 7

## Fitting and Using Glass In Rotators

To focus the clock hands accurately place the chrome surface of each glass gobo so it faces in towards the metal clock face.

### SETTING THE TIME

DHA will supply the Real Time Clock with the gobo clock face and hands fitted for front projection unless otherwise specified.

To set the time it is necessary to remove the rotator unit from the lantern and manually rotate the glass gobos to the appropriate positions.

Refer to the illustrations on the next page for the correct gobo settings for front and back projection. If the unit is changed from front to back projection change the direction of the hands using the switches on the motor housing.

Care should be taken when carrying out any alterations as both the unit and the gobos get very hot during use. Poorly handled hot glass will easily break, and spring clips are likely to jump from their housing when hot. It is therefore important that you wait until the unit has cooled before removing it from the lantern. When replacing the unit in the lantern ensure that the motor housing is not located over the lamp house.

# Setting the Time

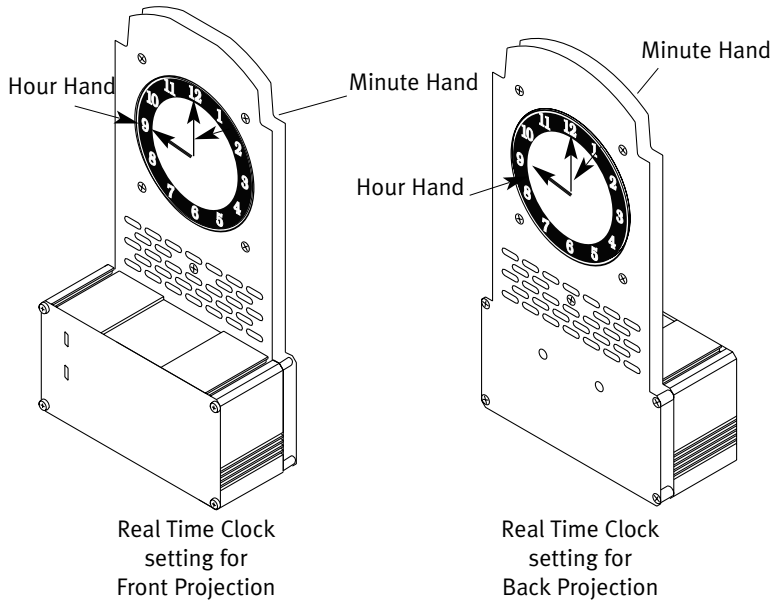

# 5

## General Precautions

Glass gobos are inherently more fragile than their metal equivalents. Incorrect use can result in an accelerated deterioration of the fine chrome surface and even breakage of the glass substrate. It is imperative to follow these simple guidelines to ensure good results.

### 1 Choose a Suitable Lantern

Glass gobos are most successfully used in luminaires with a relatively cool running temperature. Consequently, they are not recommended for use in standard, high-wattage theatre lanterns. Generally, lanterns should be not more than 1kW in power and even lower if they have an axial lamp orientation or secondary reflectors. A 'condensor' optical system is a desirable feature, both to protect the gobo from the heat of the lamp and to improve projection quality.

### 2 'Flat-Field' the Lantern

It is essential that prior to the use of a glass gobo in any luminaire, the luminaire is adjusted to produce a 'flat field'. This means that the intensity of the beam is even across its whole area with no 'hot spots'. The lamp position can usually be adjusted in relation to the reflector to achieve this result. It should be noted that the lantern will not be at its perceived brightest when the 'flat-field' position is reached.

Failure to correctly adjust the field will produce patchy deterioration of the chrome surface and a build up of stresses within the gobo due to temperature variations across the illuminated surface. In some cases this could cause the gobo to break.

### 3 Use the Correct Gobo Holder

Glass gobos should only be used with specially designed gobo holders. These holders allow for the expansion of the glass disc as its temperature rises. If there is no allowance for expansion the glass will be put under pressure and will almost certainly break.

Glass gobo holders are available from DHA stockists or from the supplier of the luminaire.

## General Precautions

### 4 **'Pre-Warm' the Gobo**

In all cases, and particularly for higher wattage lanterns, it is good practice to 'pre-warm' the gobo by holding the dimmer at a low level prior to bringing the luminaire up to full power. Luminaires with discharge sources should be powered up (once flat-fielding has been completed) with the gobo installed so that it can warm up with the luminaire.

DHA cannot accept liability for failure of any glass gobo where these requirements have not be met in full. If in doubt consult DHA for advice.

# 6

## Important Safety Notes

In the interests of safety all Gobo Rotators are provided with a fixing point for a safety chain. This must be used.

This product is supplied for professional, indoor use by competent technicians. Isolate from mains supply before removing any cover.

Caution: When installed, this device will absorb heat from the lantern and may rapidly become hot. Allow time to cool before handling.

No user-serviceable parts inside. Please contact DHA for further product support.

## 7

## Fitting Reference

## GOBO ROTATORS

Unit	Gobo Size	Lantern
RTR002	B	Strand Cantata <sup>1</sup> , Prelude <sup>2</sup> , Optique <sup>3</sup>
RTR003	B	Altman 1KL <sup>4</sup> ETC Source Four (zoom and fixed) Strand SL Range
RTR004	B	CCT Silhouette <sup>3</sup> , Project, Freedom Selecon Pacific 12/28 <sup>7</sup> , 23/50 Selecon Pacific 20, 30, 40, 50, 90 Selecon Zoomspot 1200
RTR005	M or D <sup>5</sup>	CCT Helios, Minuette Lee Colortran Windsor Profile Zero 88 Focus
RTR006	M or D <sup>5</sup>	ADB DS51, DS54, DW54 Coemar Accento
RTR007	B	Altman Shakespeare Teatro Comma

## DOUBLE GOBO ROTATORS

Unit	Gobo Size	Lantern
RTR202/V	2 x B	Strand Cantata <sup>1</sup> , Prelude <sup>2</sup> , Optique <sup>3</sup>
RTR203/V	2 x B	Altman 1KL <sup>4</sup> ETC Source Four (zoom and fixed) Strand SL Range
RTR204/V	2 x B	CCT Silhouette <sup>3</sup> , Project <sup>3</sup> , Freedom <sup>7</sup> Lee Colortran Windsor Profile Selecon Pacific 12/28 <sup>7</sup> , 23/50 Selecon Pacific 20, 30, 40, 50, 90 Selecon Zoomspot 1200
RTR207/V	2 x B	Altman Shakespeare
RTR209/V	2 x B	Robert Juliat Range <sup>4,6</sup> Strand Alto 2K <sup>4,6</sup>
RTR203 Clock	3 x B	ETC Source Four <sup>8</sup> Strand SL Range
RTR204 Clock	3 x B	Selecon Pacific (not 12/28) <sup>8</sup>

## ROTATOR ADAPTOR PLATES

(adapt standard rotators to fit other lanterns)

<b>Unit</b>	<b>adapts</b>	<b>to fit lantern</b>
RAP001	RTR002 or 202	ADB Europe series
RAP002	RTR002 or 202	Teatro Tratto, Tipo
RAP003	RTR005 or 006	Vision 650W Spotlight Milano Sintesi 650W
RAP004	RTR002 or 202	Strand Alto <sup>4</sup> , Cadenza <sup>4</sup>
RAP005	RTR002 or 202	Spotlight Milano Sintesi 1200W Vision 1200W
RAP006	RTR005 or 006	Selecon Acclaim 650W, Astral
RAP007	RTR002 or 202	Robert Juliat 400, 600 & 700 series
RAP008	RTR005 or 006	ETC Source Four Junior

### Key

- <sup>1</sup> May require gate adaptor – please contact our sales department for details.
- <sup>2</sup> Newer models with sliding gate covers only.
- <sup>3</sup> May require spacer kit (SP/CCT).
- <sup>4</sup> Unsuitable for extended use due to intense heat at the gobo gate (particularly with 230V lamp).
- <sup>5</sup> Do not take glass gobos.
- <sup>6</sup> Blackened to maximise optical performance.
- <sup>7</sup> Uses M size gobos so needs GAD adaptor.
- <sup>8</sup> Must be 70W CDM if cibachrome face is required.

8

Declaration of Conformity

DECLARATION OF CONFORMITY

According to ISO/IEC Guide 22 and EN 45014

Manufacturer's Name DHA Lighting Limited.

Manufacturer's Address  
DHA Lighting Limited  
284 - 302 Waterloo Road  
London SE1 8RQ  
England

declares, that the product(s):

Product Name: GOBO ROTATOR, VARISPEED  
Model Number(s): RTR-002V /-003V /-004V /-005V /-006V /-007V

Product Options: 12V DC ONLY

conform(s) to the following Product Specifications:

Safety: Relevant clauses of  
EN 60-065: 1993

EMC: EN50081-1 Emissions  
EN50082-1 Immunity  
EN61000-3-2 Harmonics

Supplementary Information:

The products herewith comply with the requirements of the Low Voltage Directive 73/23/EEC and the EMC Directive 89/336/EEC. The products were tested in a typical configuration.

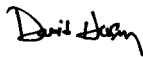

David K Hersey  
Director

Date 30/8/96

European Contact:

DHA Lighting Limited  
284 - 302 Waterloo Road London SE1 8RQ England  
Tel +44 (0)171 771 2900 Fax +44 (0)171 771 2901

# Declaration of Conformity

## DECLARATION OF CONFORMITY

According to ISO/IEC Guide 22 and EN 45014

**Manufacturer's Name** DHA Lighting Limited.

**Manufacturer's Address**  
DHA Lighting Limited  
284 - 302 Waterloo Road  
London SE1 8RQ  
England

declares, that the product(s):

**Product Name:** DOUBLE GOBO ROTATOR, VARISPEED  
**Model Number(s):** RTR-202V /-203V /-204V /207V

**Product Options:** 12V DC ONLY

conform(s) to the following **Product Specifications:**

**Safety:** Relevant clauses of  
EN 60-065: 1993

**EMC:** EN50081-1 Emissions  
EN50082-1 Immunity  
EN61000-3-2 Harmonics

**Supplementary Information:**

The products herewith comply with the requirements of the Low Voltage Directive 73/23/EEC and the EMC Directive 89/336/EEC. The products were tested in a typical configuration.

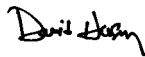

David K Hersey  
Director

Date 30/8/96

European Contact:

DHA Lighting Limited  
284 - 302 Waterloo Road London SE1 8RQ England  
Tel +44 (0)171 771 2900 Fax +44 (0)171 771 2901

# Declaration of Conformity

## DECLARATION OF CONFORMITY

According to ISO/IEC Guide 22 and EN 45014

Manufacturer's Name                      DHA Lighting Limited.

Manufacturer's Address  
DHA Lighting Limited  
284 - 302 Waterloo Road  
London SE1 8RQ  
England

declares, that the product(s):

Product Name:    GOBO ROTATOR, FIXED-SPEED  
Model Number(s): RTR-002 /-003 /-004 /-005 /-006 /-007

Product Options: 120V or 230V 50/60Hz AC & All Motor Speeds  
conform(s) to the following Product Specifications:

Safety:                      Relevant clauses of  
                                    EN 60-065: 1993

EMC:                        EN50081-1    Emissions  
                                    EN50082-1    Immunity  
                                    EN61000-3-2   Harmonics

### Supplementary Information:

The products herewith comply with the requirements of the Low Voltage Directive 73/23/EEC and the EMC Directive 89/336/EEC. The products were tested in a typical configuration.

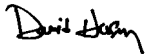

David K Hersey  
Director

Date 25/10/96

European Contact:

DHA Lighting Limited  
284 - 302 Waterloo Road    London SE1 8RQ England  
Tel +44 (0)171 771 2900 Fax +44 (0)171 771 2901

284 – 302 WATERLOO ROAD LONDON SE1 8RQ [tel](tel:+44(0)2077712900) +44(0)20 7771 2900 [fax](tel:+44(0)2077712901) +44 (0)20 7771 2901  
[e-mail](mailto:sales@dhalighting.co.uk) sales@dhalighting.co.uk [website](http://www.dhalighting.co.uk) www.dhalighting.co.uk [isd](tel:+44(0)2074019202) +44(0)20 7401 9202