

Read this manual carefully and understand all of  
it's contents before you assemble and load the truss



# **PROLYTE USER MANUAL**

## **FOR THE X30D - X30V - H30D - H30V**

## **X40D - X40V AND H40V TRUSSES**

Version 1.0, March 2005



**PROLYTE PRODUCTS**  
STAGING - RIGGING - TRUSSING

Industriepark 9, 9351 PA Leek, The Netherlands  
phone: +31 (0)594 85 15 15, fax: +31 (0)594 85 15 16  
e-mail: [info@prolyte.com](mailto:info@prolyte.com), website: [www.prolyte.com](http://www.prolyte.com)

## **Multi Purpose truss instructions**

### **1. PREFACE**

This preface explains how to interpret the symbols and text styles in this manual.

Warnings and cautions contain important information that can protect you, the trusses, and the construction. Always read warnings and attentions.

Notes contain additional information. Some notes contain basic information for inexperienced users. Others provide extra information or tips for experienced users

### **WARNING**

The information in a warning protects against bodily harm or loss of life

### **CAUTION**

The information in an caution protects against damage to the truss or optional external parts

**Note:** The information in a note provides supplementary information for inexperienced and/or advanced users

This manual has been written for all the users of Prolyte trusses\*. Make sure that you read and understand this manual completely before using the trusses. This manual should be accessible for everyone assembling, disassembling or using the trusses. Save this manual for later use. At request, we can send you an additional manual or you can download it from the Prolyte website.

\* Truss: One or more modules, generally horizontal, assembled to carry load over a distance, primarily in flexure

**Multi Purpose truss instructions**

**CONTENTS**

1	PREFACE .....	2
2	INTRODUCTION .....	4
3	IDENTIFICATION .....	4
4	TRANSPORT AND WAREHOUSING .....	7
5	SPECIFICATIONS .....	8
6	VISUAL INSPECTION .....	9
7	ASSEMBLY .....	9
8	GENERAL USE .....	10
9	STANDARD TRUSS-LENGTHS .....	10
10	LOADING TABLES .....	11
11	SLINGING TRUSSES .....	11
12	DO'S AND DON'TS .....	12
13	LEGISLATION .....	13
14	SAFETY INSPECTIONS INTERVAL .....	13
15	INSPECTION CRITERIA .....	14
16	DISASSEMBLY .....	17
17	MAINTENANCE .....	17

## **Multi Purpose truss instructions**

### **2. INTRODUCTION**

The 30- and 40-series trusses are designed as a light to medium duty truss-system for use in the installation, rental and exhibition market that desire strength and flexibility as well as compactness. The possible applications for the multi purpose truss are numerous. Due to its versatility, truss from the multi purpose series is popular in the rental as well as the exhibition market. Their strength related to their relatively small dimensions make it ideal for complex structures like displays or booths. The Prolyte trusses described in this manual are not designed for lifting people! Adequate load-reduction and safety precautions, according to local legislation, must be taken when people are lifted.

Multiple Prolyte trusses can be coupled to increase the span or, with the help of a box-corner\*, corners and cross-sections can be created. The conical coupling system allows for fast, efficient and highly aesthetic assembly of permanent and temporary structures.

### **3. IDENTIFICATION**

The X and H series trusses are distinguished by the number of embossed rings in the coupler receiver (see figure 1)

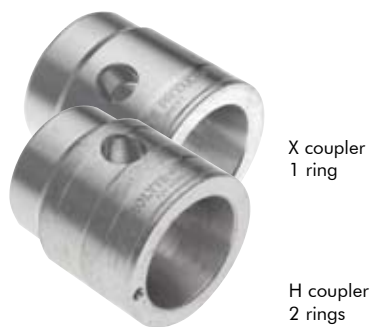

**Figure 1 Embossed rings**

\*Box-corner: A square box that enables the creation of 2 , 3 , 4 , 5 or 6-way corners

**Multi Purpose truss instructions**

**Prolyte truss X30D**

Prolyte X-truss can be recognized by the CCS 6 ® couplers with the Prolyte-logo at the ends of the truss and it has one ring below the pin-holes. The **X30D** truss is of triangular type:  
 239mm (w) x 207mm (h) (centre to centre)  
 290mm (w) x 258mm (h) (connection outside)  
 Chords: tubes 51x2 mm  
 Lattice and braces: 16x2mm

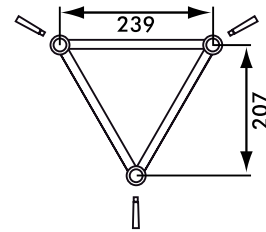

**Figure 2 X30D dimensions**

**Prolyte truss X30V**

Prolyte X-truss can be recognized by the CCS 6 ® couplers with the Prolyte-logo at the ends of the truss and it has one ring below the pin-holes. A **X30V** truss has a triangular cross-section with chords:  
 239mm (w) x 239mm (h) (centre to centre) 290mm (w) x 290mm (h) (connection outside).  
 Chords: tubes 51x2 mm.  
 Lattice and bracers: 16x2mm.  
 See figure 3

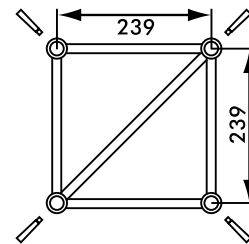

**Figure 3 X30V dimensions**

**Prolyte truss H30D**

Prolyte H-truss can be recognized by the CCS 6 ® couplers with the Prolyte-logo at the ends of the truss and it has two rings below the pin-holes. The **H30D** truss is of triangular type:  
 239mm (w) x 207mm (h) (centre to centre)  
 287mm (w) x 255mm (h) (connection outside)  
 Chords: tubes 48.3x3 mm  
 Lattice and braces: 16x2mm  
 See figure 4

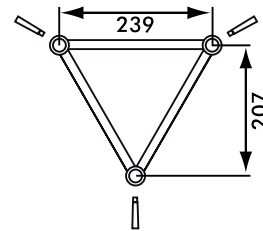

**Figure 4 H30D dimensions**

**Prolyte truss H30V**

Prolyte H-truss can be recognized by the CCS 6 ® couplers with the Prolyte-logo at the ends of the truss and it has two rings below the pin-holes. A **H30V** truss has a triangular cross-section with chords:  
 239mm (w) x 239mm (h) (centre to centre) 287mm (w) x 287mm (h) (connection outside).  
 Chords: tubes 48.3x3 mm  
 Lattice and bracers: 16x2mm  
 See figure 5

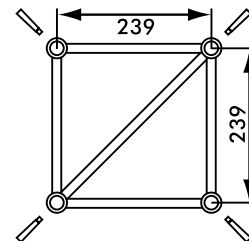
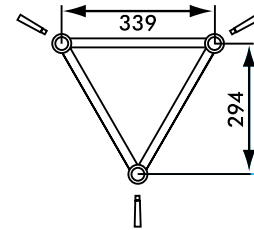

**Figure 5 H30V dimensions**

**Multi Purpose truss instructions**

**Prolyte truss X40D**

Prolyte X-truss can be recognized by the CCS 6 ® couplers with the Prolyte-logo at the ends of the truss and it has one ring below the pin-holes. The **X40D** truss is of triangular type:  
 339mm (w) x 294mm (h) (centre to centre)  
 390mm (w) x 345mm (h) (connection outside).  
 Chords: tubes 51x2 mm  
 Lattice and bracers: 20x2mm  
 See figure 6



**Figure 6 X40D dimensions**

**Prolyte truss X40V**

Prolyte X-truss can be recognized by the CCS 6 ® couplers with the Prolyte-logo at the ends of the truss and it has one ring below the pin-holes. The **X40V** has a triangular cross-section with chords:  
 339mm (w) x 339mm (h) (centre to centre)  
 390mm (w) x 390mm (h) (connection outside).  
 Chords: tubes 51x2 mm  
 Lattice and bracers: 20x2mm  
 See figure 7

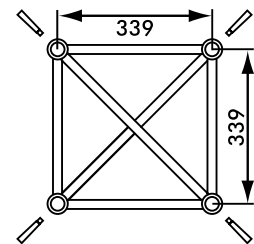

**Figure 7 X40V dimensions**

**Prolyte truss H40D**

Prolyte H-truss can be recognized by the CCS 6 ® couplers with the Prolyte-logo at the ends of the truss and it has two rings below the pin-holes. The **H40D** truss is of triangular type:  
 339mm (w) x 294mm (h) (centre to centre)  
 387mm (w) x 342mm (h) (connection outside).  
 Chords: tubes 48.3x3 mm  
 Lattice and bracers: 20x2mm  
 See figure 8

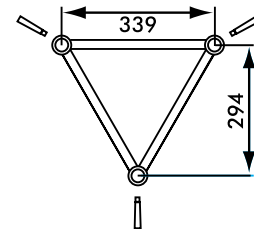

**Figure 8 H40D dimensions**

**Prolyte truss H40V**

Prolyte H-truss can be recognized by the CCS 6 ® couplers with the Prolyte-logo at the ends of the truss and it has two rings below the pin-holes. The **H40V** has a triangular cross-section with chords:  
 339mm (w) x 339mm (h) (centre to centre)  
 387mm (w) x 387mm (h) (connection outside).  
 Chords: tubes 48.3x3 mm  
 Lattice and bracers: 20x2mm  
 See figure 9

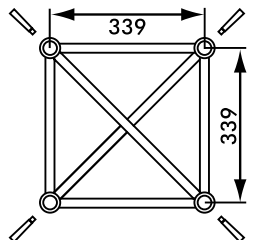

**Figure 9 H40V dimensions**

**Multi Purpose truss instructions**

**4. TRANSPORT AND WAREHOUSING**

**WARNING**

Always wear safety shoes and protective gloves when moving, assembling or disassembling trusses

1. Treat the trusses with care. Don't drop them, don't drag them around the floor and don't throw sections on top of each other.
2. Prevent damage from sharp edges such as the forks of a forklift.
3. Truss dollies can be highly effective means for transportation and storage, while providing the truss-sections with some extra protection.
4. Vertical transportation or stocking of trusses can be hazardous for reasons of falling.

**Multi Purpose truss instructions**

**5. SPECIFICATIONS**

TYPE	Material	Cross-section single tubes				Conical coupler system		Permissible normal force in the single tubes		Tuss height (center-center)	Tuss width (center-center)	Cross-section complete truss			Permissible internal force complete truss				Dead weight	
		Chord tubes	Diagonals	Chord tubes	Diagonals	Chord tubes	Diagonals	Chord tubes	Diagonals			A	Iy	Iz	My	Mz	N	Oz / Vz		Oy / Vy
		D	t	A	D	t	A	N	N	h	b	ly	lz	kNm	kNm	kN	kN	kN	kN	g
H30D	AlMgSi1 F31 / EN AW 6082 T6	48	3	4,241	16	2	0,880	30,54	7,04	20,70	23,90	12,72	1057,3	1047,9	6,32	7,30	91,61	8,62	4,98	5
H30V	AlMgSi1 F31 / EN AW 6082 T6	48	3	4,241	16	2	0,880	30,54	7,04	23,90	23,90	16,96	2095,9	2095,9	14,60	14,60	122,15	9,95	9,95	6,3
H40D	AlMgSi1 F31 / EN AW 6082 T6	48	3	4,241	20	2	1,131	30,54	9,05	29,40	33,90	12,72	2104,8	2089,8	8,98	10,35	91,61	11,08	6,40	5
H40V	AlMgSi1 F31 / EN AW 6082 T6	48	3	4,241	20	2	1,131	30,54	9,05	33,90	33,90	16,96	4179,5	4179,5	20,70	20,70	122,15	12,80	12,80	6,9
X30D	AlMgSi1 F31 / EN AW 6082 T6	51	2	3,079	16	2	0,880	22,17	7,04	20,70	23,90	9,24	771,2	763,1	4,59	5,30	66,50	8,62	4,98	3,8
X30V	AlMgSi1 F31 / EN AW 6082 T6	51	2	3,079	16	2	0,880	22,17	7,04	23,90	23,90	12,32	1526,3	1526,3	10,60	10,60	88,67	9,95	9,95	5,1
X40D	AlMgSi1 F31 / EN AW 6082 T6	51	2	3,079	20	2	1,131	22,17	9,05	29,40	33,90	9,24	1531,6	1519,4	6,52	7,51	66,50	11,08	6,40	4,1
X40V	AlMgSi1 F31 / EN AW 6082 T6	51	2	3,079	20	2	1,131	22,17	9,05	33,90	33,90	12,32	3038,9	3038,9	15,03	15,03	88,67	12,80	12,80	5,6

Figure 10 Specifications

**Multi Purpose truss instructions**

**6. VISUAL INSPECTION**

Inspect the trusses and coupler parts on visual wear or damage of any kind before assembling or using the trusses.

**WARNING**

Never use truss-sections or coupler parts that are damaged or have excessive wear

**7. ASSEMBLY**

1. Inspect de trusses and coupler parts as described above.
2. Put the conical couplers (CCS6-600) in the conical tube-ends of the truss. Notice the wide side of the truss-pinhole points outward or upward See figure 11.
3. Fix the coupler with the tapered steel truss pins (CCS6-603 for repeated assembly) or (CCS6-604 for longer periods of assembled use).
4. Slightly manoeuvre the truss-sections towards each other.
5. Use a red copper hammer of approx. 600gr to hammer the pins in place. Prevent wear on pins and dents in the truss.
6. Lock the truss pins in place with R-clips (CCS6-605) or M8 self-locking nuts (BM-M8-SN).

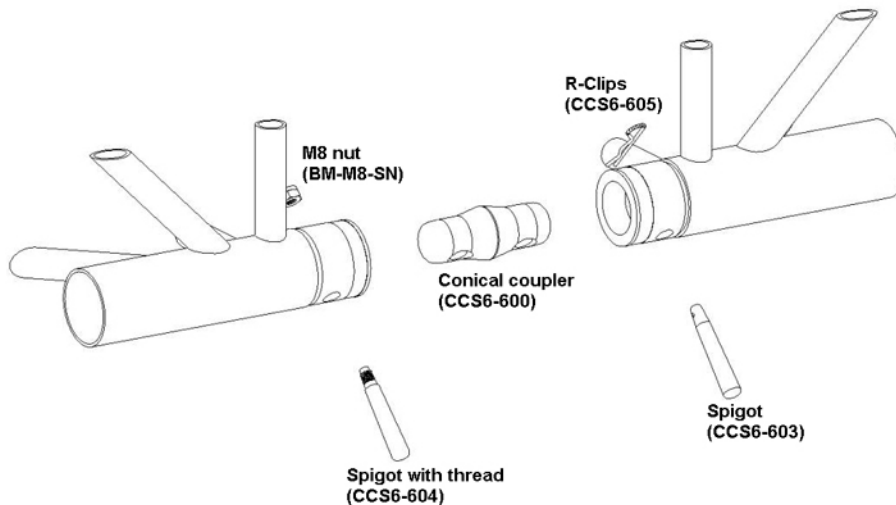

**Figure 11 Coupling system**

**Multi Purpose truss instructions**

**8. GENERAL USE**

These Multi purpose trusses are designed to build structures to support loads like loading from lighting, sound and set-items as well as drapes, cyclorama's etc. They are designed for repetitive use in demanding circumstances as the Lighting & Sound industry.

**WARNING**

- The spans and the loads applied may NEVER exceed the values as given in the tables in Appendix 1 of this manual.
- Prolyte Trusses are NOT particularly designed to lift people. Adequate load-reduction and safety precautions, according to local legislation, must be taken when people are lifted.

When building 3-dimensional structures using 3 way-corners, loading values from the tables should be halved.

**9. STANDARD TRUSS-LENGTHS**

Different Truss types come in different standard lengths. See figure 12

H30D/V [mm]	X30D/V [mm]	H40D/V [mm]	X40D/V [mm]
250	250	250	250
290	290	500	500
500	500	750	750
710	710	810	810
742	742	1000	1000
750	750	1500	1500
1000	1000	2000	2000
1500	1500	2500	2500
2000	2000	3000	3000
2500	2500	3500	3500
3000	3000	4000	4000
3500	3500	4500	4500
4000	4000	5000	5000
4500	4500		
5000	5000		

**Figure 12 Standard truss lengths**

For Ordering numbers see Appendix 2

**Multi Purpose truss instructions**

**10. LOADING TABLES**

The maximum load a truss can handle is different for every truss and every length. A detailed loading table for every truss is added in Appendix 1:

- The total load applied should not exceed the data in the loading table
- Loading figures are only valid for static loads and spans with two supporting points.  
Spans must be supported at each end
- If dynamic loads or more supporting points are applied contact a structural engineer or Prolyte
- Self weight of the truss is already taken into account

For all other situations as well as for assembled constructions a static report is required.

**11. SLINGING TRUSSES**

There are many ways to sling a truss, however there are many ways of slinging that require a significant load reduction or result in an instable situation. Prolyte advises to sling trusses as shown below (see figure13)

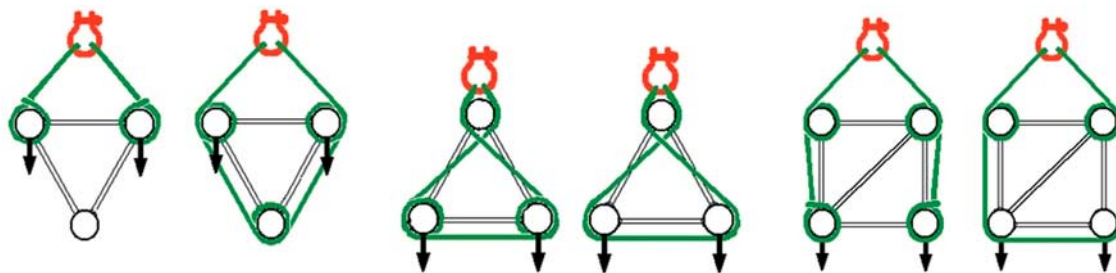

Only at end braces

**Figuur 13 Approved slinging methods**

**Multi Purpose truss instructions**

**12. DO'S AND DON'TS**

1. Check if all truss-pins and safety's are in the right position before putting load to the truss-span.
2. Know and check the maximum allowable loading configuration at the chosen span (see appendix 1).
3. Know and check the load that is to be applied.
4. Always spread the load evenly on both of the lower chords.  
**Note: When loading only one side, decrease the allowable load by half!**
5. Don't overload a truss. It is unsafe to do so and illegal in most countries.
6. Prevent horizontal or side loading of the truss at all times. Prevent wind loading.
7. Always suspend or support the truss at the node points of the lower chords or near the end braces of each truss (see figures 14 and 15 below)

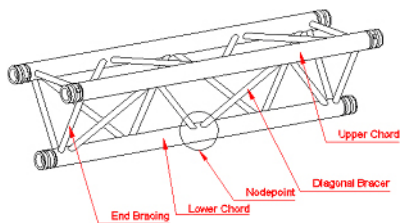

**Figure 14 Node points**

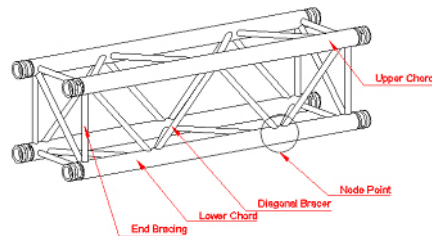

**Figure 15 Node points**

8. Lifting-chains and wires must be vertical at all times when lifting the truss.
9. All hoists that lift one single truss-structure should run at the same speed.
10. Protect polyester round slings that support truss or load from heat-sources (spots, beams, pyro's and lasers). Temperatures over 100 °C are normal for spots but dangerous to polyester round slings!
11. Use sleeved wire rope slings for suspension or as safety's when temperature can cause hazards.
12. Protect the truss from abrasive surfaces or cutting effects from wire ropes.
13. Prevent horizontal compressive forces on the chords from the applied slinging methods. Put basket hitches always next to bracer tubes
14. Prevent damage to the chords by over-tightening C-clamp bolts or rotation of clamped spots around the chord.
15. Reduce the allowable loading on truss and hoists when complete grids or structures are to be moved or raked.
16. Long spans with UDL supported on more than 2 hoists or columns have the specific reaction forces of continuous beams, with the central reactions being considerably higher than the ones at the ends.

## Multi Purpose truss instructions

### 13. LEGISLATION

Prolyte products are made in compliance with the following standards:

- DIN 4112 Temporary structures; code of practice for design and construction.
- DIN 4113-1 Aluminium constructions under predominantly static loading; static analysis and structural design.
- DIN 4113-2 Aluminium constructions under predominantly static loading.
- EN 287-2 Approval testing of welders-Fusion Welding. Part 2: Aluminium and aluminium alloys.
- EN 288-4 Specification and approval of welding procedures for metallic materials part 3: Welding procedures tests for the arc welding of aluminium and aluminium alloys.
- EN 729-3 Quality requirements for welding. Fusion welding of metallic materials. Part 3: Standard quality requirements.
- ISO 10042 Arc-welded joints in aluminium and its weldable alloys.
- NEN 2063 Arc welding. Fatigue loaded structures. Calculation of welded joints in unalloyed and low-alloy steel up to and including FE 510 (FE52).
- NEN 6710 Technical principles for building structures. Aluminium structures. Basic requirements and basic rules for calculations of predominantly statically loaded structures.
- TGB 1990 Technical principles for building structures. General requirements.
- ANSI E1.2-2000 Entertainment Technology: Design, Manufacture and Use of Aluminium Trusses and Towers.
- BS 7906 - 2:2000:Code of practice for use of aluminium and steel trusses and towers. - 2:2000:Specifications for design and manufacturing of aluminium steel trusses and towers.
- BS 8118 1991. Structural use of aluminium Part 1. Code of practice for design.
- NEN 5509 User manuals - Content, structure, formulation and presentation
- NEN-EN 755-1 Aluminium and aluminium alloys. Extruded rod/bar, tube and profiles. Part 1: Technical conditions for inspection and delivery
- NEN-EN 755-2 Aluminium and aluminium alloys. Extruded rod/bar, tube and profiles. Part 2: Mechanical properties

### 14. SAFETY INSPECTIONS INTERVAL

Prolyte encourages careful documented inspection by a competent person at least once a year and possibly more often if the circumstances or intensity of use require so. Prolyte's criteria are more detailed and more severe than those of the upcoming international standard for truss in the entertainment. If the truss is used as lifting equipment, the inspection interval should be according to the machine directive and local legislation for inspection. If the truss is used as construction equipment, the inspection interval should be according to the building code and local legislation for inspection.

## WARNING

Prolyte trusses have to be checked and inspected visually for damage or any other aspect, that might negatively affect the safety of the truss, prior to each time of use.

**Multi Purpose truss instructions**

**15. INSPECTION CRITERIA**

Responsibility and liability for the safe use of truss, lies predominantly with the user itself!

**WARNING**

Prolyte trusses have to be checked and inspected visually for damage or any other aspect, that might negatively affect the safety of the truss, prior to each time of use.

**A. GENERAL**

1. Absence of any identification showing: manufacturer, truss-type and date of production.
2. Permanent (plastic) distortion of the module by rotation, bending, torsion or any other deformation from the original design.
3. Welds showing cracks or other sudden discontinuities. The open heel in the bracing welds in the 30er and 40er series is normal and calculated in the TÜV approval.
4. Any incomplete welds – apart from those in the heel-area of the diagonal bracings.
5. Reduction of welded areas through wear or tear by more than 10%.
6. Excessive corrosion, reducing the total truss cross-section area by more than 10%.

**B. CHORDS**

1. Any of the chords being broken, torn or partly absent.
2. Any of the chords being bent out off the center-line by more than 5°. (See fig 16).
3. Any bending of the chord-ends next to the coupler, resulting in the use of force when connecting two modules.
4. Scratches, cuts or wear on the chord's surface reducing the chord's section area by more than 10%
5. Any scratch or cut on the chord deeper than 1mm and longer than 10 mm in no matter what direction.
6. Any smooth round hole reducing the chord's section area by more than 5%
7. Permanent (plastic) deformation by ovalness or dents of the round tube diameter by more than 10%.

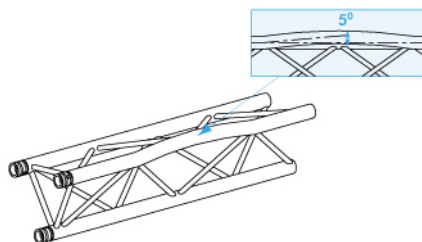
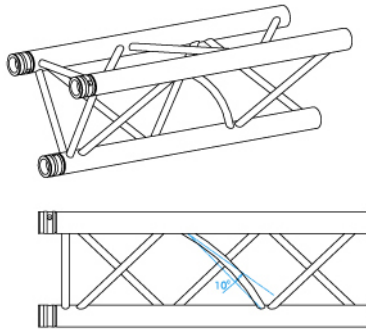

**Figure 16 Bending of the main chords**

**Multi Purpose truss instructions**

**C. BRACES**

1. Any of the diagonals, end-braces or cross-braces being broken or partly absent.
2. Any of the braces being bent out of the centerline by more than 10° (see figure 17).
3. Scratches, cuts or wear on the braces surface reducing the braces section area by more than 15%
4. Any scratch or cut on the braces deeper than 0,5 mm and longer than 10 mm in no matter what direction.
5. Any round hole reducing the chord's section area by more than 5%
6. Permanent (plastic) deformation by ovalness or dents of the round tube diameter by more than 10%



**Figure 17 Bending of the braces**

**D. CONICAL COUPLER SYSTEM**

1. Missing, cracked or broken parts of the welded 601-receiver-fitting.
2. Cracked or partly broken welds between chord and receiver fitting.
3. Any oval-shaped wear on the holes for the CCS-603 conical spigot pins in the trusses or the conical coupler (see figure below)

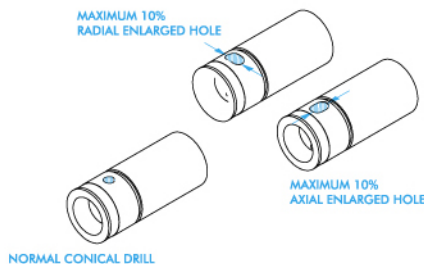

**Figure 18 Oval-shaped holes**

4. Out of line rotation of the spigot-pin holes within a CCS-600-coupler or between two adjoining by more than 2°.
5. Bending of the chord ends with the coupler-receiver parts by more than 5°, resulting in difficulties in joining two truss-modules during assembly.
6. Wear on the coupler or receiver part resulting in cross-section area loss of more than 10%.
7. Deformation or distortion in the chord-area next to the weld of the receiver part. Overload in compression leads to outward buckling effects, overload in tension leads to constriction in the chord tube next to the welds.
8. Any scratch, cut or hammer blow on the receiver deeper than 2mm and longer than 10 mm in no matter what direction.
9. Excessive corrosion in the connection. In systems staying assembled for periods longer than a year indoor or one summer season outdoors it is advised to use new and freshly galvanized spigot pins only, to prevent any hazard that might arise from galvanic corrosion.

**Multi Purpose truss instructions**

**E. CONICAL SPIGOT PINS**

These steel pins are so called "consumables" this means that these parts are most susceptible to wear by the use of hammers etc. Also they are indicators of excessive overload, showing compression-surfaces and bending.

1. Reduction in diameter by more than 10%.
2. Cuts, dents, scratches and other damage to the smooth surface of the pin (see figure 19).
3. Burrs, "mushrooms" and other extending sharp edges on the narrow end of the pin.
4. Deformation by hammering, leading to closure of the safety-clip hole, or screw thread.
5. Loss of zinc coating on any part of the spigot pin, causing it to corrode.
6. Self-locking nuts which show clear loss of the nylon-locking mechanism by wear may not be used.

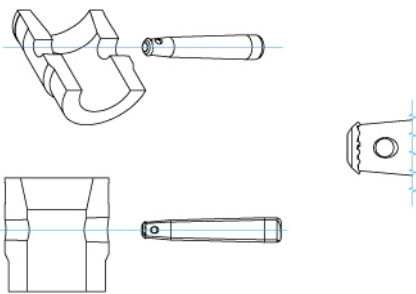

**Figure 19 Damaged spigot pins**

## Multi Purpose truss instructions

### 16. DISASSEMBLY

1. Remove the load of the truss and place the truss on the ground.
2. When the span is resting on the ground, the R-clips or M8-selflocking nuts can be removed.
3. Manoeuvre the truss a little if needed to release the tension from the coupling parts.
4. Undo the steel truss pins as much as possible in one strike, preferably with a red copper hammer.

### CAUTION

Never use sharp tools as screwdrivers to disengage truss-pins from the couplers.  
A truss-pin in opposite direction will do the job just fine.

### 17. MAINTENANCE

Like any other item being used in situations where wear and tear are normal, trusses also need maintenance. Special attention must be given to the coupler components. These components are to be considered as "consumables" in the sense that these parts will show more wear in use, and might from time to time have to be replaced with new ones.

Coupler components:

- Regularly smooth the surface with fine sandpaper
- Keep them slightly lubricated with silicone oil, spray or similar lubrication  
**Note: Any lubricant used should not be "sticky", thus preventing the gathering of dirt, dust or small parts of debris.**
- Prevent the drying of spray-painted coupler components when in position, this has a negative effect on the precise fit (a drop of paint can be five times as thick as the CNC-tolerance setting and can act as glue when pressed in between the coupler surfaces)

### WARNING

Neglect of maintenance and/or inspection at regular intervals of the truss, might eventually lead to the use of unsafe products, resulting in risk of property damage, personal injury or even death.

When modules are found with any aspects that negatively influence the safety, these should be taken out of service and clearly marked in such a way that it prevents the possibility of use by mistake. To ensure this respect for safety is however greatly depending on company procedures and/or the dry-hire client's proper information and education. Just a piece of duck-tape on a damaged is not sufficient as this is too easily removed.